

Sony Centre in Berlin



The Sony Centre at Potsdamer Platz in Berlin is a complex of seven individual buildings with a total floor space of 132,500 square metres. This lively urban ensemble comprises Sony's new European headquarters on Kemper Platz, a high-rise office on Potsdamer Platz, other buildings for offices, apartments, shops and restaurants, the historic Esplanade hotel, a film centre, which also houses the Marlene Dietrich Collection and, an entertainments precinct with an IMAX 3D cinema. On the four subterranean levels which take up a large part of the triangular 26,444 square metre plot, are the service areas for the individual buildings, parking decks and stations for local and long-distance railways.



The steel and glass roof seems to float above the Forum.

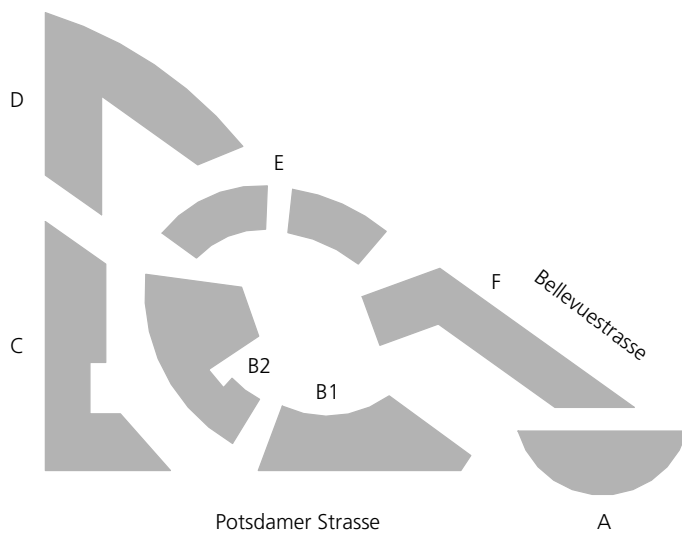

- A High-rise office of Deutsche Bahn
- B1 Film centre / 'Deutsche Kinemathek'
- B2 CineStar film theatre and IMAX
- C Office building of Sanofi-Synthelabo
- D Sony's European headquarters
- E Office building on Bellevuestrasse / Sony Music
- F Esplanade Residence

The complex, built to the competition-winning design of Helmut Jahn, boasts a 4,000 square metre covered plaza, known as the 'Forum'. This elliptical arena is a brand new type of open-air space for Berlin and, one that looks very firmly into the 21st century in terms of function and design. Instead of providing the four surrounding buildings with their own, separate courtyards, the architect placed them all together to form a single large space. Rimmed by restaurants, cafés and shops, the Esplanade, the Film House and the entertainments precinct, this forum is a broad, urban square, open to the public. Free of the restrictions of enclosed spaces, this covered, naturally ventilated plaza can be used for a variety of public and cultural events.



*Office tower on
Potsdamer Platz.*

Integrated into the complex are the parts of the Hotel Esplanade that survived the bombing in the Second World War. Two famous halls of the grand hotel – the Breakfast Salon and the Imperial Salon – had to be physically moved in 1996 to accommodate the development plan and, to enable a widening of Potsdamer Strasse. The old hotel, now



a listed building, stands behind steel and glass walls, as if in a showcase, protected by a standing seam roof of matt, abrasion-blasted stainless steel sheet (grade EN 1.4404). As the historic building could not bear the load of the new, 12,500-tonne 'Esplanade-Residence', the frame of the new apartment hotel straddles it over a width of 60 metres: most of the apartments are suspended from the twelve-metre high roof frame, consisting of two main trussed girders and six 4.40-metre high transverse girders.



The 4,000 m², light-flooded 'Forum' in the Sony Centre.

Two 260-tonne steel roof frames straddle the parts of the old Esplanade hotel that survived the war.

The roof of the IMAX cinema, tilted towards the Forum, and a number of wall surfaces of the 3D film theatre and the film centre are clad with a stainless steel mesh of wire and round bars. These are interlaced in such a way as to leave 50 percent of the surface free. Depending on the angle of the light, this flexible façade can sometimes appear semi-transparent, revealing the frame beneath, and at other times as an entirely closed, solid surface. The façade of the film centre can even be used as a projection screen.

The changing effects of light and shade on the stainless steel mesh façade lend lightness and movement.

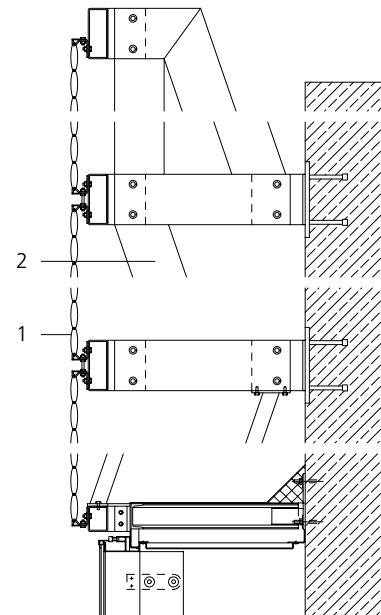

Suspension system for the stainless steel mesh
 1 Stainless steel mesh, grade EN 1.4404, made of 7 x 1 mm flat wire and 7 mm dia. round bars
 2 Galvanised steel frame



Another recurring element in the façades at the Sony Centre is profiled 1.5 mm stainless steel sheet (grade EN 1.4401). The surfaces are finely polished (grit size 320) and brushed. In the ellipse-shaped Forum this 'zigzag' sheet is curved to create a wave effect and emphasise the sweep of the space. Profiled panels were also used throughout on the long punctuated façade of the Film House and the 'Deutsche Kinemathek' on Potsdamer Strasse.

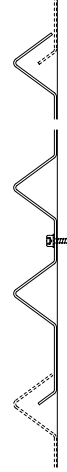

'Zigzag sheet', curved to emphasise the sweep of the façades around the Forum.

The profiled stainless steel panels articulate and lend structure to the regular, punctuated façade.

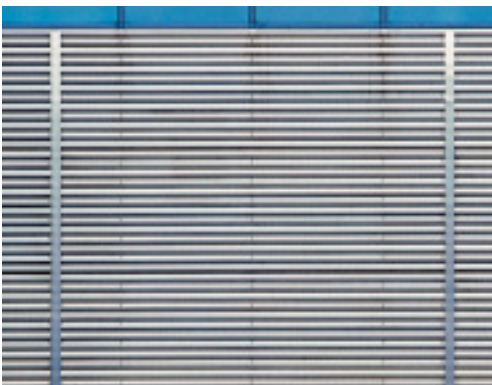



Narrow bands of profiled stainless steel sheet also separate the storey-height glass panels on the façade, specially designed for the Sony Centre. Only 135 mm deep, this construction is used on the high-rise office on Potsdamer Platz, on Sony's headquarters building and on the office building of Sanofi-Synthelabo. The façade is reinforced by interior and exterior 15 mm double glass fins. Stainless steel fixing points create a structural connection between the glazing and the uprights in the façade frame. Alternate façade units are fitted with power-operated open-out-and-tilt vents for ventilation and smoke control in the rooms behind.

The vertical glass fins, attached with stainless steel fixing points, reinforce the glass façade. In the curved areas the fins are mounted on the exterior, on the flat areas they are on the inside.

- Section of the glass façade, Buildings A and C
- A Section with interior glass fins
 - B Section with exterior glass fins
 - C Section with stainless steel parapet
 - 1 Solar insulating glass
 - 2 Stainless steel sheet, grade EN 1.4401, edges bent, 1.5 mm, polished (grit size 320) and brushed surface
 - 3 Stainless steel sheet, grade EN 1.4401, patterned, 2 mm, polished (grit size 320) and brushed surface
 - 4 Glass fin
 - 5 Stainless steel bracket with fixing points
 - 6 Attachment to façade

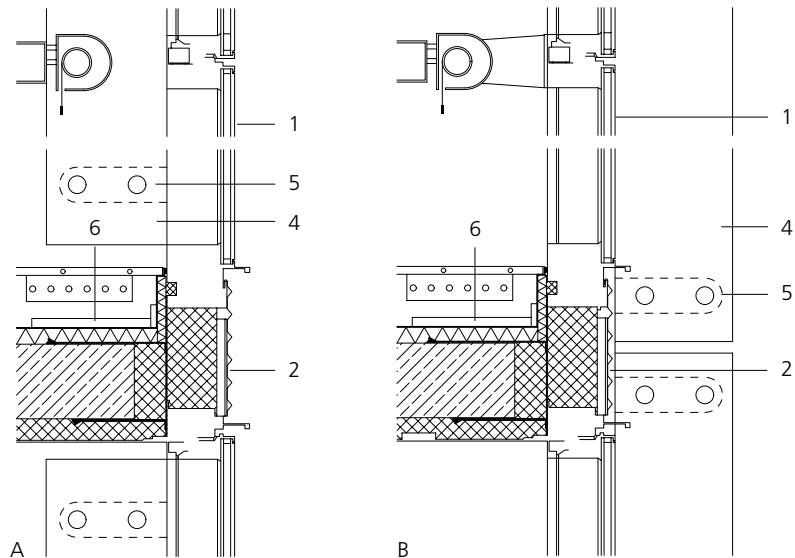

Stainless steel is also used on the façade of the Sanofi-Synthelabo building, as continuous bands marking out the parapet levels. The 2 mm thick sheets are fixed to perimeter frames and suspended flush with the façade in a mullion and transom construction. Patterned squares, 30 x 30 mm, articulate the 1094 mm high and approx. 1200 mm wide units. The surface is vertically polished (grit size 320) and brushed.

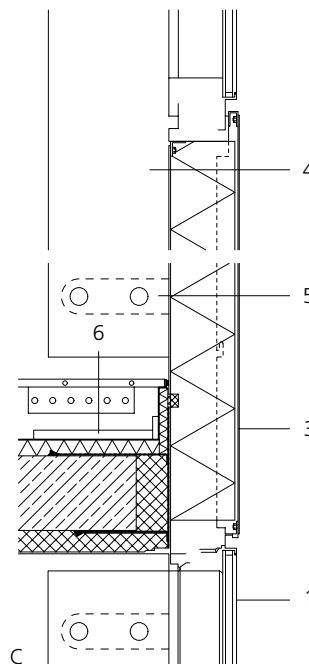
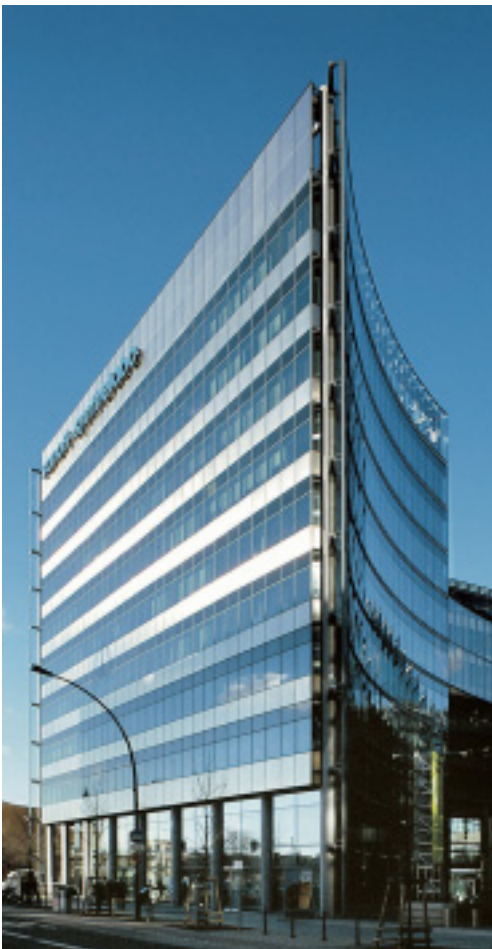
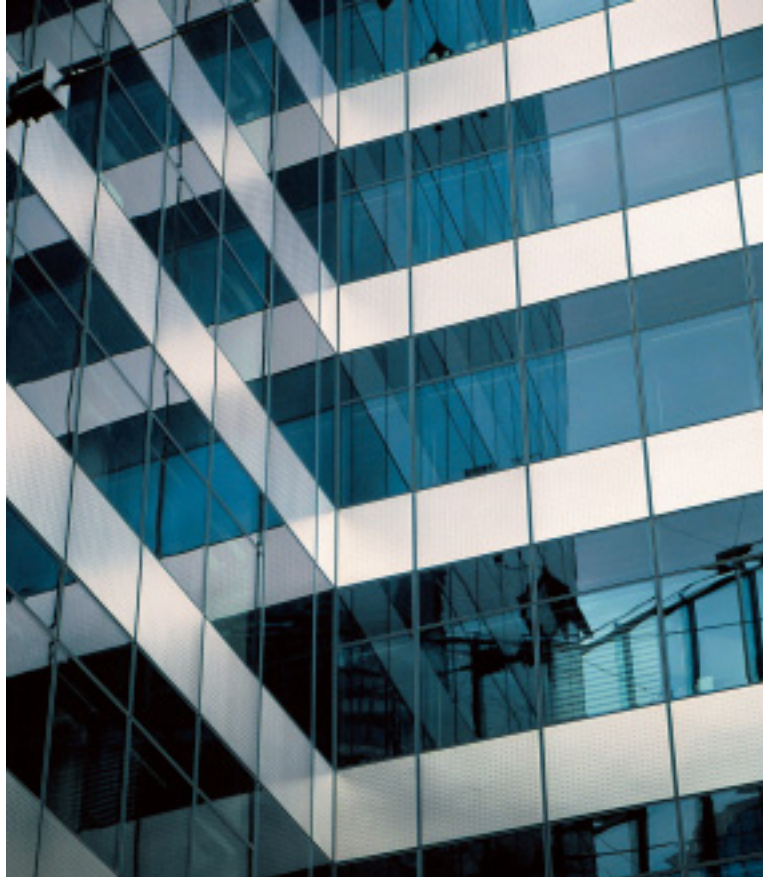

Patterned stainless steel sheet at parapet level: another variation on the stainless steel and glass theme in the Sony Centre.

“The spatial dynamic and variety contrasts with the minimalised design and technological character of the building structures. Built mainly of glass, the seven buildings exploit the characteristic features of this material such as transparency and permeability to light.” (Helmut Jahn)



Horizontal glass fins on the inside reinforce the façade structure of stainless steel compression struts and tensile rods.



Euro Inox

Diamant Building, Bd. A. Reyers 80,
1030 Brussels, Belgium

Phone +32 2 706 82 67

Fax +32 2 706 82 69

E-mail info@euro-inox.org

Internet www.euro-inox.org

Client: SONY and project partners

Tishman Speyer and Kajima,
associated in BE-ST Bellevuestrasse Development
GmbH & Co. First Real Estate KG

Architect: Murphy/Jahn, Chicago, USA

Project development: Tishman Speyer, Berlin, Germany

General contractor: Hochtief AG, Berlin, Germany

Text and layout: Martina Helzel, circa drei,
Munich, Germany

Translation: Ingrid Taylor, Munich, Germany

Photos: SONY, Berlin (cover, p. 2 centre, p. 7 right)
circa drei, Munich (p. 1, p. 2 top and bottom, p. 3,
p. 4 bottom, p. 6)

Metallwarenfabrik Neustadt GmbH, Neustadt,
Germany (p. 4 top)

Josef Gartner GmbH & Co. KG, Gundelfingen,
Germany (p. 5, p. 7 left)

Drawings: Josef Gartner GmbH & Co. KG,
Gundelfingen, Germany (p. 5 and 6)